



## Review Article

# Clinical characteristics and epilepsy in genomic imprinting disorders: Angelman syndrome and Prader–Willi syndrome

Tzong-Shi Wang<sup>a</sup>, Wen-Hsin Tsai<sup>b,c</sup>, Li-Ping Tsai<sup>b,c</sup>, Shi-Bing Wong<sup>b,c,\*</sup>

<sup>a</sup>Department of Psychiatry, Taipei Tzu Chi Hospital, Buddhist Tzu Chi Medical Foundation, New Taipei, Taiwan, <sup>b</sup>Department of Pediatrics, Taipei Tzu Chi Hospital, Buddhist Tzu Chi Medical Foundation, New Taipei, Taiwan, <sup>c</sup>School of Medicine, Tzu Chi University, Hualien, Taiwan

### ABSTRACT

Angelman syndrome (AS) and Prader–Willi syndrome (PWS) are considered sister imprinting disorders. Although both AS and PWS congenital neurodevelopmental disorders have chromosome 15q11.3-q13 dysfunction, their molecular mechanisms differ owing to genomic imprinting, which results in different parent-of-the-origin gene expressions. Recently, several randomized controlled trials have been proceeded to treat specific symptoms of AS and PWS. Due to the advance of clinical management, early diagnosis for patients with AS and PWS is important. PWS is induced by multiple paternal gene dysfunctions, including those in MKRN3, MAGEL2, NDN, SNURF-SNPRPN, NPAP1, and a cluster of small nucleolar RNA genes. PWS patients exhibit characteristic facial features, endocrinological, and behavioral phenotypes, including short and obese figures, hyperphagia, growth hormone deficiency, hypogonadism, autism, or obsessive–compulsive-like behaviors. In addition, hypotonia, poor feeding, failure to thrive, and typical facial features are major factors for early diagnosis of PWS. For PWS patients, epilepsy is not common and easy to treat. Conversely, AS is a single-gene disorder induced by ubiquitin-protein ligase E3A dysfunction, which only expresses from a maternal allele. AS patients develop epilepsy in their early lives and their seizures are difficult to control. The distinctive gait pattern, excessive laughter, and characteristic electroencephalography features, which contain anterior-dominated, high-voltage triphasic delta waves intermixed with epileptic spikes, result in early suspicion of AS. Often, polytherapy, including the combination of valproate, levetiracetam, lamotrigine, and benzodiazepines, is required for controlling seizures of AS patients. Notably, carbamazepine, oxcarbazepine, and vigabatrin should be avoided, since these may induce nonconvulsive status epilepticus. AS and PWS presented with distinct clinical manifestations according to specific molecular defects due to genomic imprinting. Early diagnosis and teamwork intervention, including geneticists, neurologists, rehabilitation physicians, and pulmonologists, are important. Epilepsy is common in patients with AS, and after proper treatment, seizures could be effectively controlled in late childhood or early adulthood for both AS and PWS patients.

**KEYWORDS:** *Angelman syndrome, Epilepsy, Genomic imprinting, Prader–Willi syndrome*

Submission : 02-May-2019  
Revision : 03-Jun-2019  
Acceptance : 03-Sep-2019  
Web Publication : 31-Oct-2019

## INTRODUCTION

Both Angelman syndrome (AS) and Prader–Willi syndrome (PWS) are associated with chromosome 15q11.2-q13 dysfunction and are considered sister imprinting disorders [1]. Although both congenital disorders map to the same chromosome locus, their molecular mechanisms, and clinical phenotypes differ because of genomic imprinting. The clinical phenotypes of AS are more restricted than those of PWS in neurological dysfunction, including cognitive impairment, seizures, and ataxia, which are also present in PWS patients with less severity. Conversely, PWS patients develop multiple

behavioral and endocrinological disorders, including autistic and obsessive–compulsive symptoms, growth hormone deficiency, and hypogonadism [1,2]. The seizure is a cardinal manifestation of AS with characteristic electroencephalography (EEG) pattern, which could aid in the early diagnosis [3]. Instead, the seizure types and EEG patterns of PWS patients

### \*Address for correspondence:

Dr. Shi-Bing Wong,  
Department of Pediatrics, Taipei Tzu Chi Hospital,  
Buddhist Tzu Chi Medical Foundation, 289, Jianguo Road,  
Xindian District, New Taipei, Taiwan.  
E-mail: [wongshibing@tzuchi.com.tw](mailto:wongshibing@tzuchi.com.tw)

This is an open access journal, and articles are distributed under the terms of the Creative Commons Attribution-NonCommercial-ShareAlike 4.0 License, which allows others to remix, tweak, and build upon the work non-commercially, as long as appropriate credit is given and the new creations are licensed under the identical terms.

For reprints contact: [reprints@medknow.com](mailto:reprints@medknow.com)

**How to cite this article:** Wang TS, Tsai WH, Tsai LP, Wong SB. Clinical characteristics and epilepsy in genomic imprinting disorders: Angelman syndrome and Prader–Willi syndrome. *Tzu Chi Med J* 2020;32(2):137-44.

Access this article online	
<b>Quick Response Code:</b> 	<b>Website:</b> <a href="http://www.tcmjmed.com">www.tcmjmed.com</a>
	<b>DOI:</b> 10.4103/tcmj.tcmj_103_19

are more assorted [4,5]. Recently, several randomized controlled trials have been proceeded to treat specific symptoms of AS and PWS, such as AZP-531 for hyperphagia [6], oxytocin (OXT) for behavior problems of PWS [7], and gaboxadol for the neurodevelopment of AS [8]. Due to the advance of clinical management, early diagnosis for patients with AS and PWS is important. Therefore, the present review aimed to introduce the clinical phenotypes, molecular mechanisms, seizure semiology, EEG patterns, and treatments of AS and PWS.

## CLINICAL FEATURES OF ANGELMAN SYNDROME AND PRADER–WILLI SYNDROME

AS is a severe neurodevelopmental disorder induced by the loss of function of the ubiquitin-protein ligase E3A (*UBE3A*) gene, which is expressed from the maternal chromosome 15 only, and the estimated incidence is 1/12,000–20,000 [9-11]. Typically, AS patients present with psychomotor delay since the age of 6 months, and this disorder is associated with feeding difficulties and muscular hypotonia [12]. Most children with AS walk independently after 3–4 years of age with a distinguishing gait pattern – a puppet-like, jerky quality with an out-toed, wide-based stance with pronated ankles [13]. Moreover, AS patients display a specific behavioral phenotype as excessive laughter and happy grimacing, which are introduced by social interaction and often associated with a protruding tongue [14]. Usually, microcephaly and seizure develop in the 1<sup>st</sup> 3 years of life [3,12]. Seizures and declined physical mobility is the leading lifelong cardinal problems for AS patients. Obesity has been noted in some patients after teenage but is not a common finding [15]. AS-related mortality exhibits a bimodal distribution, with some early deaths attributable to the complications of severe seizures or accidental events. Unlike PWS patients, endocrinopathy and sudden death are uncommon in AS patients. The lifespan of AS patients is considerably long beyond childhood [16].

Unlike AS in which the symptoms are mostly restricted to the neurological system, PWS is a multisystem disorder caused by the loss of function of multiple genes from paternal chromosome 15q11-13. Affected infants present with marked hypotonia since birth, which results in feeding difficulties and failure to thrive. The characteristic facial features, including narrow bifrontal diameter, almond-shaped palpebral fissures, narrow nasal bridge, and thin upper vermilion, may be observed since birth [2]. Moreover, neonatal hypotonia, feeding difficulties, and typical facial appearance are major factors leading to an early diagnosis of PWS. Majority of the patients exhibit delayed motor and language milestones, as well as intellectual disability (mean intelligence quotient, 60–70). Since toddler and childhood, excessive appetite develops, and patients gradually become obese [17]. Hypothalamic dysfunction is another cardinal symptom of PWS, which is manifested as temperature dysregulation, enhanced pain tolerance, lack of satiety that, perhaps, induces food-seeking behavior, and sleep-disordered breathing, including central and obstructive sleep apnea [18]. Besides, hypothalamic dysfunction results in central hypothyroidism, central adrenal insufficiency, growth hormone deficiency,

and hypogonadotropic hypogonadism [2,18]. PWS patients exhibit a characteristic behavioral phenotype, including temper tantrums, stubbornness, controlling and manipulative behavior, compulsivity, and difficulty in changing routines, which even fulfill the criteria for the diagnosis of autistic spectrum disorder (ASD) [2]. However, autistic and compulsive behaviors are rare in AS patients. Veltman *et al.* reported that 38 out of 150 (25.3%) PWS patients and 2 out of 104 (1.9%) AS patients had ASD as a morbidity [19]. The neurodevelopmental disabilities of the PWS patients, such as mental retardation, autistic features, and emotional symptoms, persist into adulthood and pose marked challenges and burdens for their caregivers [20-23]. The estimated incidence of PWS is 1/10,000–30,000. The PWS-related mortality rate is higher than that in controls with intellectual disability. A population study estimated the PWS-related mortality rate at 3% per year [24]; however, with enhanced supportive care and proper diet to control body weight, PWS patients may live a full life.

## GENETICS FOR ANGELMAN SYNDROME AND PRADER–WILLI SYNDROME

AS and PWS are caused by the same chromosome dysfunction, mostly caused by deletion, on 15q11.2-q13; this region contains several genes and has a typical parent-of-the-origin expression, termed genomic imprinting, which implies monoallelic and parent-of-origin-dependent expression of a subset of genes [Figure 1]. The mechanism of genomic imprinting involves differential epigenetic markings of the alleles, primarily from parental allele-specific DNA methylation and chromatin modification during gametogenesis in the male and female germline [25,26]. Thus, the loss of function of the active allele cannot be compensated by another allele, making the imprinted genes more vulnerable. Four different mechanisms cause imprinted gene dysfunction, including gene mutation, chromosome deletion or duplication, uniparental disomy (UPD), and imprinting defect [27]. UPD is caused by meiotic and mitotic nondysfunction events and makes both copies of a chromosome pair from the same parent. The imprinting defect makes wrong parental allele methylation, and further disarrays the imprinted gene function. AS and PWS are typical examples of imprinting disorders, for which the parental origin of the affected chromosome 15 would be the determining factor for clinical phenotypes [28].

AS is a single-gene disorder caused by the loss of function of maternally expressed gene *UBE3A* in neuronal cells [9]. The *UBE3A* gene comprises 16 exons and encodes E6-AP, an E3 ubiquitin ligase [11]. Unlike the PWS gene expression, which is regulated by DNA methylation, the imprinted expression of *UBE3A* is regulated by small RNA host gene 14 (small nucleolar RNA host gene 14 [*SNHG14*]; previously termed *UBE3A-ATS*), a noncoding antisense transcript that is initiated at the *SNRPN* promoter [29]. In neuronal cells, *SNHG14* transcription extends to the *UBE3A* gene and interferes with *UBE3A* expression on the paternal chromosome, and only maternal *UBE3A* is functional. However, *UBE3A* is biallelically expressed in nonneuronal cells [30]. E6-AP transfers ubiquitin from an E2 ubiquitin-conjugating enzyme to its protein substrates, which is called ubiquitylation, and processes

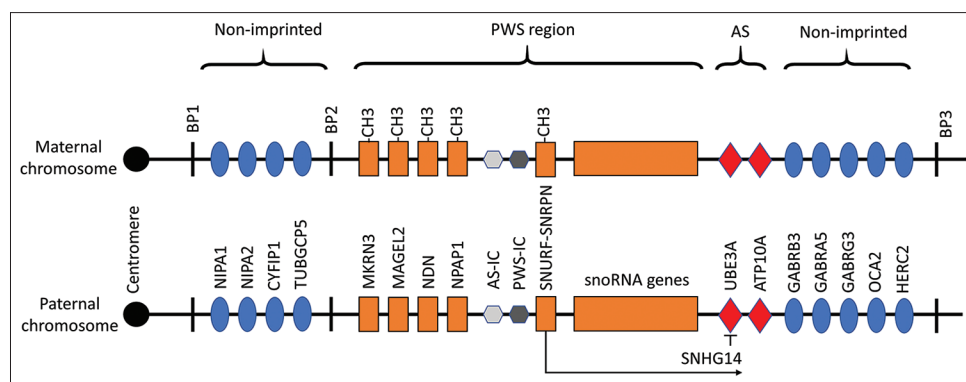

**Figure 1:** Genes in chromosome 15q11.2-q13. This chromosomal region begins from four non-imprinted genes (blue eclipses) and follows by Prader-Willi syndrome region, including five paternal-expressed functional genes (*MKRN3*, *MAGEL2*, *NDN*, *NPAP1*, *SNURF-SNRPN*) and a family of paternal-expressed snoRNA genes (orange squares). Those five functional genes in maternal allele are methylated and nonfunctional. Prader-Willi syndrome/Angelman syndrome imprinting center is included in this region. The Angelman syndrome region includes two maternal-expressed genes, *UBE3A* and *ATP10A* (red diamonds), followed by five non-imprinted genes, including *GABRB3*, *GABRA5*, *GABRG3*, *OCA2*, and *HERC2* (blue eclipses). BP: Breaking point, IC: Imprinting center, snoRNA: Small nucleolar RNA, *SNHG14*: Small nucleolar RNA host gene 14

the protein substrates into specific functions, including membrane transport, transcriptional regulation, or degradation [16]. From *Drosophila* and mice experiments, several protein levels are altered by E6-AP knockout or overexpression, such as ECT2, p53, p27, HR23A, Arc, and ephexin-5; p27 and p52 are involved in regulating neuronal cell proliferation and survival, whereas ephexin-5 and Arc are involved in synapse formation and remodeling [16]. Thus, the clinical phenotypes of AS are primarily constricted in neurodevelopmental aberrations.

The PWS region of chromosome 15 has five paternally expressed genes, including *MKRN3*, *MAGEL2*, *NDN*, *NPAP1*, *SNURF-SNRPN*, which could encode polypeptides and a cluster of small nucleolar RNA genes (snoRNAs), which mediate post-transcriptional, sequence-specific methylation that dictates mRNA folding and stability [18,31]. The *NDN* gene encodes the protein neccidin, which is vital for serotonergic and GABAergic neuron development, as well as central respiratory control [32,33]. The *MAGEL2* protein is highly expressed in the hypothalamic supraoptic, paraventricular, and suprachiasmatic nuclei. In fact, *MAGEL2* knockout mice demonstrated delayed pubertal onset and declined fertility, as well as decreased wakefulness and motor activity, which corroborates PWS patients [34]. SNORD116 is one of the snoRNAs in the PWS region that accounts for several PWS phenotypes. SNORD116-null mice were anxious, deficient in motor learning, with growth retardation and moderate hyperphagia [34]. SNORD116 microdeletions have been reported in three individuals, all exhibiting some cardinal features of PWS, including neonatal hypotonia, infantile feeding problems, rapid weight gain after 2 years of age, hyperphagia, hypogonadism, mental retardation, and speech and behavioral problems; however, these patients do not have typical facial features of PWS, as well as growth retardation [2]. The clinical phenotypes of PWS are wide, including neurological, endocrinological, and metabolic symptoms, which are, perhaps, caused by the loss of expression of multiple functional genes on 15q11.2-q13.

The three major molecular mechanisms inducing PWS are paternal deletion (accounts for 65%–75% of patients),

maternal UPD (20%–30% of patients), and imprinting defect (1%–3% of patients) [2]. In Taiwan, a retrospective study conducted on 52 PWS patients revealed 45 (87%) with paternal deletion, 5 (10%) with maternal UPD, and 2 (4%) with an imprinting defect [35]. The clinical phenotypes of patients with paternal deletions or maternal UPD differ. Patients with UPD are less likely to exhibit hypopigmentation or the characteristic facial appearance of PWS [36]. As reported by researchers, patients with UPD had an elevated risk of psychiatric illness and bipolar disorder, whereas patients with paternal deletions had markedly lower full-scale IQ and verbal IQ [37]. For AS patients, four different molecular defects include the deletion of maternal chromosome 15q11.2-q13 (75% of patients), paternal UPD (1%–2% of patients), imprinting defects (1%–3% of patients), and *UBE3A* mutations (5%–10% of patients) [38]. Patients with AS induced by maternal deletions typically have relatively severe clinical manifestations, including microcephaly, seizures, and hypopigmentation, possibly caused by the haploinsufficiency of the downstream non-imprinted genes, including *GABRB3*, *GABRA5*, *GABRG3*, and *OCA1*. Patients with *UBE3A* mutations recapitulate all the core symptoms of AS, implying that the phenotypes of AS mostly correlate with *UBE3A* gene dysfunction [16].

### SEIZURE PREVALENCE AND SEMIOLOGY OF PATIENTS WITH ANGELMAN SYNDROME AND PRADER-WILLI SYNDROME

Although AS and PWS are sister imprinting disorders, the diverse molecular mechanisms distinguish their clinical phenotypes, including seizure prevalence and semiology. We summarized the prevalence of various seizure types in patients with AS and PWS [Table 1]. Epilepsy occurs in 75%–95% of AS patients and seizures could develop before the diagnosis of AS [39-41]. The age of seizure onset may be early up to 3 months (mean onset age, 1–2 years) [41,42]. The seizure types of AS patients markedly vary and transform over time. Infantile spasm could be the first presentation of epilepsy in some AS patients [39,40,42]. Other seizure types, including generalized tonic-clonic seizure (GTCS),



**Table 1: Prevalence of various seizure types in patients with AS and PWS**

	AS	PWS	Reference
Overall prevalence	75-95%	4-33%	39, 40, 41, 44, 47, 48, 49
Atonic	4-41%	0-22%	40, 42, 44, 47, 48
Generalized tonic-clonic	13-40%	60-88% *4% in 48	40, 41, 42, 43, 44, 45, 48*, 49
Absence	26-37%	10-13%	40, 41, 43, 44, 49
Complex partial	16-32%	10-11% *92% in 48	40, 41, 47, 48*, 49
Myoclonic	12-36%	0-8%	40, 41, 42, 43, 48
Tonic	9%	0	40, 47
Secondarily generalized	8%	4%	40, 48
Focal motor	6-17%	10%	40, 41, 43, 49
Infantile spasms	2-9%	0	39, 40, 42, 47, 49
Lennox-Gastaut syndrome	1%	0	40, 47, 49

AS, Angelman syndrome; PWS, Prader-Willi syndrome. \*Seizure types of PWS patients from the report by Vendrame *et al.* were inconsistent with other case series [48]

absence seizures, febrile seizures (FS), myoclonic seizures, atonic seizures, and complex partial seizures, have also been observed, and over half of the AS patients have >2 seizure types [43-45]. The seizure frequency is high in AS patients and could occur >10 times a week [40]. Nonconvulsive status epilepticus (SE), such as atypical absence SE and myoclonic SE, are also frequently observed [41,42,46]. Nonconvulsive SE could result in cognitive decline, which could misguide physicians and lead to the misdiagnosis of metabolic disorders [41].

Conversely, a seizure occurs in only a minority of PWS patients (4%–33%) [5,44,47-49]. In PWS patients, most seizures develop before the age of 6 years [4,5,47,48]; however, in some patients, the age of seizure onset is delayed to teenage years [4,48]. In a study examining 142 PWS patients in Japan, 31 experienced seizures, wherein FS accounted for 17 (12%) cases, and only 9 (6.3%) patients were diagnosed with epilepsy [47]. In another cohort of 92 PWS patients in the United States, Vendrame *et al.* reported only 24 (26%) patients with epilepsy [48]. The seizure types of PWS patients with epilepsy vary in the literature. As established by studies, GTCS is the leading seizure type of PWS patients with epilepsy [4,44,47,49]. However, 22 out of 24 PWS patients with epilepsy in a study had focal epilepsy, which mostly included staring spells with eye deviation [48]. Typically, seizures in PWS patients are regarded a spectrum of generalized seizure disorder, including FS and GTCS [49], in which SE is rarely observed, and patients with multiple seizure types are common [4,47].

Genotypes of both AS and PWS affect epilepsy phenotypes and severity. Those patients with AS caused by maternal deletion of chromosome 15q11.3-q13 would face a higher risk of epilepsy than those caused by *UBE3A* mutations or paternal UPD [39,46]. Shaaya *et al.* reported that 88% of patients with deletion have seizures, whereas 57% and 40% of patients with *UBE3A* mutations and paternal UPD have seizures, respectively [39]. The interaction of *UBE3A* and *GABRB3* dysfunction due to maternal 15q11.3-q13 deletion was considered

as the cause of high seizure burden in AS patients [44], and the clinical speculation was in line with a recent study which illustrated the GABAergic *UBE3A* loss a principle cause of circuit hyperexcitability in AS mice [50]. The genotype difference of seizure prevalence in PWS patients was reported in some studies. Fan *et al.* reported that PWS patients caused by paternal deletion are more likely to experience epilepsy (18%–45%) than those caused by maternal UPD (0%–7%), probably due to their haploinsufficiency of the GABA receptor subunit cluster (*GABRB3*, *GABRA5*, and *GABRG3*) [49]. However, Takeshita *et al.* reported that 26 of 109 patients with deletion and 5 of 31 patients with maternal UPD experienced seizures ( $P = 0.35$ ), which contradicts the findings in prior studies [47]. Thus, larger cohort and meta-analyses are warranted to ascertain the correlation between epilepsy phenotypes and genotypes of PWS patients.

### ELECTROENCEPHALOGRAPH CHARACTERISTICS OF EPILEPSY WITH ANGELMAN SYNDROME AND PRADER–WILLI SYNDROME

In a case series, Boyd *et al.* extensively investigated the EEG characteristics of epilepsy in AS patients [51]; they recognized three patterns of EEG abnormalities in 19 children with AS, which are categorized by slow waves over different brain regions as follows: Pattern 1 – prolonged runs of rhythmically triphasic 2–3-Hz activity (200–500  $\mu$ V) often more prominent anteriorly, sometimes associated with discharges (ill-defined spike/wave complexes); Pattern 2 – spikes mixed with 3–4-Hz components usually >200  $\mu$ V mainly posteriorly and facilitated by, or only observed with, eye closure [Figure 2]; and Pattern 3 – persistent rhythmic 4–6-Hz activities reaching >200  $\mu$ V not related to drowsiness. These three EEG patterns have been validated in follow-up studies, and pattern 1 was observed in 60%–80% of AS patients, which persisted until adulthood [44,52,53]. Individual AS patients would have more than one EEG pattern in the same recording or at a different time, and the EEG patterns did not correspond with specific types of epilepsy [44,52]. In patients who possessed generalized high-voltage slow-wave background activities, it was difficult to control seizures [54]. Except for slow activities, hypsarrhythmia and continuous diffuse spikes and waves also occur in young AS patients, which corresponded with clinical infantile spasms and atypical absence SE, respectively [42]. Arguably, hypsarrhythmia in AS patients comprises runs of delta activities intermixing multifocal spikes or sharp waves. Compared with typical hypsarrhythmia in West syndrome, AS patients lack the fragmentation of hypsarrhythmia during sleep, with no sleep/wake correlation [55,56]. Conclusively, EEG is a sensitive tool for the early diagnosis of AS because of characteristic patterns, offering the opportunity of early etiological diagnosis [56].

In PWS patients with epilepsy, no typical EEG pattern has been observed [4]. Unlike AS patients, few PWS patients with epilepsy have slow EEG background activities and the triphasic high-voltage, anterior-dominated delta waves [4,49], except Wang *et al.* reporting 5 PWS patients presenting

persistent high-voltage 4–6-Hz activities [44]. As per reports by researchers, interictal EEG recordings reveal focal, multifocal, or generalized epileptiform discharges [Figure 3], per individual's seizure types [4,47,48]. Ictal EEG has been

scarcely reported. Verrotti *et al.* reported ictal EEG recording in 10 patients, and all had generalized spike-wave paroxysms related to GTCS, corroborating that GTCS is more common in PWS patients with epilepsy [4].

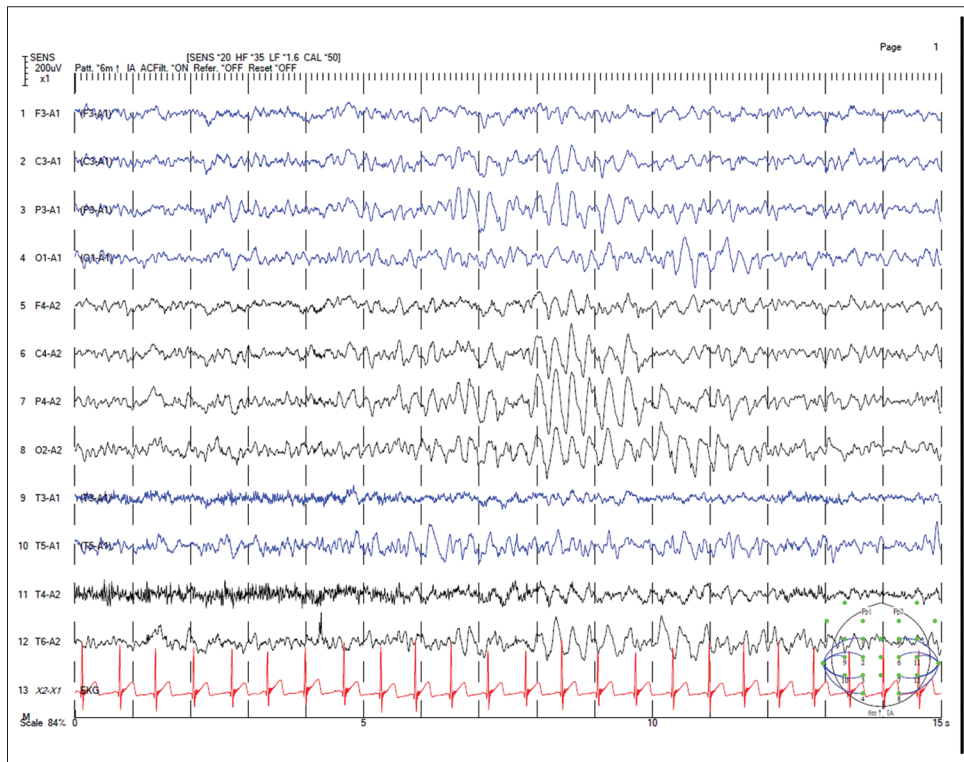

**Figure 2:** Awake electroencephalography in a 5-year-old boy with Angelman syndrome. The recording shows posteriorly-dominated 3–4-Hz high-voltage slow waves, which are characteristic for Angelman syndrome patients

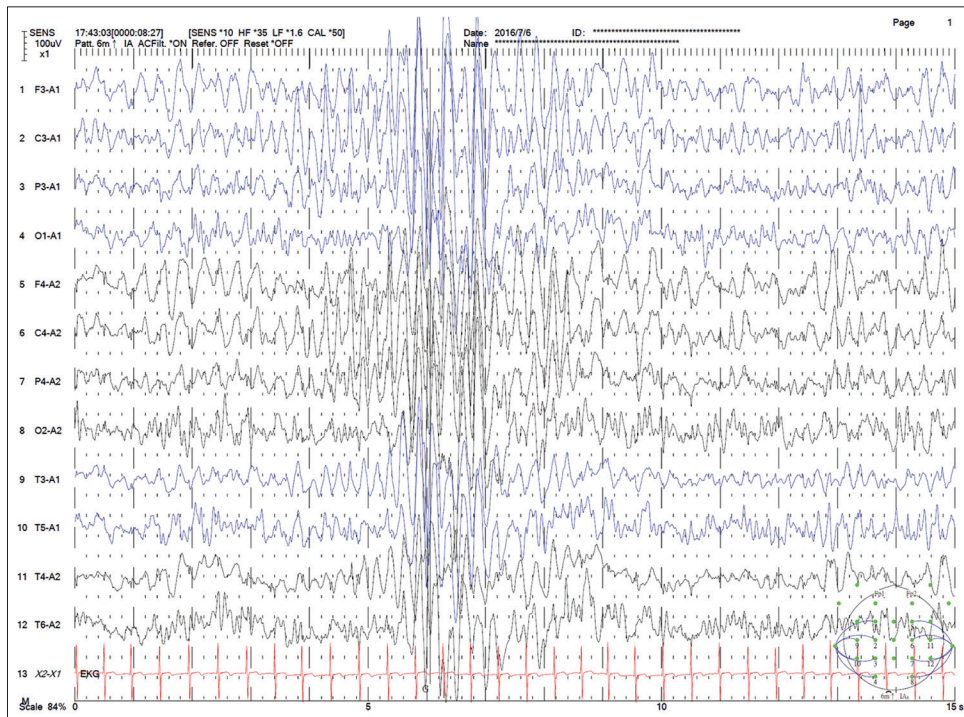

**Figure 3:** Sleep electroencephalography in a 2-year-old boy with Prader-Willi syndrome. The recording shows a short burst of generalized spike-waves and excessive beta activities over posterior head regions

## SEIZURE TREATMENT AND PROGNOSIS FOR PATIENTS WITH ANGELMAN SYNDROME AND PRADER–WILLI SYNDROME

For AS patients, controlling seizures is difficult with pharmacological treatment [55]. In a large cohort of 461 AS patients, Thibert *et al.* reported that 77% of patients with epilepsy are refractory to antiepileptic drugs (AED), and only 15% respond well to the first AED [40]. In most case series, AED polytherapy is required for better seizure control in most patients [39,40,43]. The efficacy of each AED differs in the literature. Valproate (VPA) is the leading first-line AED and is highly effective, although adverse effects also frequently develop [39,41,45]. VPA was effective in all 25 AS patients as mono- or poly-therapy; Shaaya *et al.* reported that 66.7% of patients experienced 90% seizure reduction, while 33.3% experienced 50% seizure reduction by VPA. However, 72% of patients developed adverse effects, including increased tremor, ataxia, and decline in motor skills. The adverse effects on motor ability result in a low-retention rate of VPA to 40% for AS patients [39]. Furthermore, other serious adverse effects, such as pancreatitis and decreased platelets or white blood cells, have also been reported [40].

New-generation AEDs, including levetiracetam (LEV), lamotrigine (LTG), and topiramate (TPM), are often prescribed for AS patients with epilepsy. Shaaya *et al.* reported prescribing LEV to 67% of patients, and 86% of patients exhibited a >90% seizure reduction. They reported that the retention rate of LEV was 79%, while 21% of patients developed adverse effects, primarily behavioral changes [39]. Thibert *et al.* reported that LEV was selected by 18% of participants and was the second most effective AED [40]. Shaaya *et al.* reported the efficacy of LTG in 18 of 29 patients and correlated it with the retention rate at 67% [39]. Notably, 12% and 13% of patients being administered LEV and LTG experience seizure exacerbation, respectively [40]. Franz *et al.* reported that five AS patients were successfully treated with TPM, which was well tolerated [57]. Moreover, TPM is an effective AED as per Shaaya *et al.*'s series, but it often results in adverse effects such as fatigue, irritability, and loss of appetite; the TPM retention rate was 33%, and no patient received monotherapy with TPM [39]. Benzodiazepines, including clonazepam (CZP) and clobazam (CLB), effectively controlled seizures in AS patients with epilepsy [39,40,45]. Shaaya *et al.* reported that out of 51% of patients undergoing treatment with CLB administration, 93% exhibited >90% seizure reduction, and 31% could be treated with CLB monotherapy. Moreover, side effects, such as sluggishness and aggression, were reported by 34% of patients regarding CLB; the CLB retention rate was 75% [39]. Thibert *et al.* reported that CZP has a seizure freedom rate of 24% and high tolerability. Common adverse effects, such as fatigue and hypotonia, have been reported in 8% and 6% of patients who underwent treatment, respectively [40]. Furthermore, CLB and CZP even exerted positive effects on patients' alertness and behavior in a study [45].

According to certain studies, some AEDs exaggerated seizures and even induced nonconvulsive SE in AS patients with

epilepsy, including carbamazepine, oxcarbazepine, and vigabatrin [41,55]. Moreover, phenobarbital was less effective and 32% of patients developed intolerable side effects [40]. The treatment experience with nonpharmacological treatments, including ketogenic diet, low glycemic index therapy (LGIT), and vagus nerve stimulation, is rare. Thibert *et al.* treated 8% of patients with a ketogenic diet, and only one-third reported effective results. Reportedly, the retention rate of the ketogenic diet was only 19% [40]. Furthermore, LGIT was effective in 10 of 12 patients in Shaaya *et al.*'s series, and the patients also exhibited better tolerability (retention rate, 67%) [39].

Compared with AS patients with epilepsy, seizures in PWS patients are less common and easy to treat. In some studies, FS was the leading etiology and did not require treatment, in addition, some patients had rare seizures for which rectal diazepam was used as necessary [4,5,47]. Monotherapy with VPA, LEV, LTG, TPM resulted in good seizure control in PWS patients with epilepsy [4,48]. Unlike CBZ in AS patients, which may induce seizure aggravation, CBZ was effective in PWS patients and also correlated with good tolerability [4,47,48].

The evolution of seizures is favorable in PWS patients but undetermined in AS. Although AS patients commonly develop seizures since infancy, and the seizures are typically challenging to control pharmacologically, these improve with time in some patients [42,43]. Sueri *et al.* reported that 27 out of 42 (64%) AS patients with epilepsy become seizure free at a median age of 10 years [43]. Uemura *et al.* reported that 19 out of 22 patients (82.6%) were seizure free for, at least, 3 years in the last follow-up [42]. Conversely, Laan *et al.* reported that epileptic seizures persisted in 13 out of 14 (92%) adult AS patients [53]. For PWS patients with epilepsy, freedom from seizures was attained in 20 out of 24 (83.3%) patients [48] and 32 out of 38 (84.2%) patients [4] in different studies.

Several clinical trials toward AS and PWS were executed in recent years. Two clinical trials that strove to improve neurodevelopment in AS using minocycline and levodopa have been unsuccessful [58,59]. A Phase II study for AS using gaboxadol (OV101) which is a highly selective extrasynaptic GABA receptor agonist is ongoing. Gaboxadol may restore the deficit in GABAergic tonic inhibition of AS patients and possibly benefit to their neurodevelopment and seizure control [8]. Two mechanistic approaches directly inhibiting SNHG-14 (UBE3A-ATS) with topoisomerase inhibitors or antisense oligonucleotides were developed from AS mouse models, and both would partially restore UBE3A protein [60,61]. The progress from the animal studies made the mechanistic treatment possible in the near future. For PWS, several new drugs revealed good efficacy on appetite control and weight loss, including exenatide [62], beloranid [63], and AZP-531 [6], but their effects for neuropsychological phenotypes of PWS were undetermined. OXT is one of the primary targets for intervention due to decreased OXT-expressing neurons in PWS patients and animal models [64,65]. Intranasal OXT administration improved feeding and social skills in infants and also appetite control and behavior in children with



PWS [7,66]. The long-term effects of OXT for neuropsychiatric symptoms of PWS are promising.

## CONCLUSIONS

Although AS and PWS are both chromosome 15q11.3-q13 dysfunctions, the molecular mechanisms differ in both congenital neurodevelopmental disorders because of genomic imprinting. Early diagnosis and teamwork intervention, including geneticists, neurologists, rehabilitation physicians, and pulmonologists, are important. PWS patients exhibit unique endocrinological and behavioral phenotypes, including short and obese figures, hyperphagia, autism, or OCD-like behaviors. Hypotonia, poor feeding, failure to thrive, and typical facial features are key points for the early diagnosis of PWS. Epilepsy is not common and easy to treat for PWS patients. However, AS patients develop epilepsy in their early lives, and the seizures are more difficult to control. The distinctive gait pattern and excessive laughter, as well as characteristic EEG patterns, result in the early suspicion and diagnosis of AS. Notably, AED polytherapy, including the combination of VPA, LEV, LTG, and BDZ, is often required to control seizures in AS patients. Moreover, CBZ, OXC, and VGB should be avoided and may induce nonconvulsive SE. Under proper treatment, seizures could be controlled well since late childhood or early adulthood for both AS and PWS patients.

## Financial support and sponsorship

This study was supported by Taipei Tzu Chi General Hospital TCRD-TPE-104-39 to Shi-Bing Wong.

## Conflicts of interest

There are no conflicts of interest.

## REFERENCES

- Cassidy SB, Dykens E, Williams CA. Prader-Willi and Angelman syndromes: Sister imprinted disorders. *Am J Med Genet* 2000;97:136-46.
- Cassidy SB, Schwartz S, Miller JL, Driscoll DJ. Prader-Willi syndrome. *Genet Med* 2012;14:10-26.
- Fiumara A, Pittalà A, Cocuzza M, Sorge G. Epilepsy in patients with Angelman syndrome. *Ital J Pediatr* 2010;36:31.
- Verrotti A, Cusmai R, Laino D, Carotenuto M, Esposito M, Falsaperla R, et al. Long-term outcome of epilepsy in patients with Prader-Willi syndrome. *J Neurol* 2015;262:116-23.
- Gilboa T, Gross-Tsur V. Epilepsy in Prader-Willi syndrome: Experience of a national referral centre. *Dev Med Child Neurol* 2013;55:857-61.
- Allas S, Caixàs A, Poitou C, Coupaye M, Thuilleaux D, Lorenzini F, et al. AZP-531, an acylated ghrelin analog, improves food-related behavior in patients with Prader-Willi syndrome: A randomized placebo-controlled trial. *PLoS One* 2018;13:e0190849.
- Tauber M, Boulanour K, Diene G, Çabal-Berthoumieu S, Ehlinger V, Fichaux-Bourin P, et al. The use of oxytocin to improve feeding and social skills in infants with Prader-Willi syndrome. *Pediatrics* 2017;139. pii: e20162976.
- Ochoa-Lubinoff C, Wink L, Grieco J, Visoatsak J, Burdine R, Kolevzon A, et al. STARS: STARS: A Phase 2 Adult Angelman Syndrome Clinical Trial: Randomized, Double-blind, Safety and Efficacy Study of Gaboxadol (P3.302). *Neurology* 2018; 90 (15 Suppl):P3.302.
- Vu TH, Hoffman AR. Imprinting of the Angelman syndrome gene, UBE3A, is restricted to brain. *Nat Genet* 1997;17:12-3.
- Matsuura T, Sutcliffe JS, Fang P, Galjaard RJ, Jiang YH, Benton CS, et al. *De novo* truncating mutations in E6-AP ubiquitin-protein ligase gene (UBE3A) in Angelman syndrome. *Nat Genet* 1997;15:74-7.
- Kishino T, Lalonde M, Wagstaff J. UBE3A/E6-AP mutations cause Angelman syndrome. *Nat Genet* 1997;15:70-3.
- Tan WH, Bacino CA, Skinner SA, Anselm I, Barbieri-Welge R, Bauer-Carlin A, et al. Angelman syndrome: Mutations influence features in early childhood. *Am J Med Genet A* 2011;155A:81-90.
- Zori R, Williams C, Mattei JF, Moncla A. Parental origin of del (15)(q11-q13) in Angelman and Prader-Willi syndromes. *Am J Med Genet* 1990;37:294-5.
- Williams CA. The behavioral phenotype of the Angelman syndrome. *Am J Med Genet C Semin Med Genet* 2010;154C:432-7.
- Larson AM, Shinnick JE, Shaaya EA, Thiele EA, Thibert RL. Angelman syndrome in adulthood. *Am J Med Genet A* 2015;167A:331-44.
- Buiting K, Williams C, Horsthemke B. Angelman syndrome – Insights into a rare neurogenetic disorder. *Nat Rev Neurol* 2016;12:584-93.
- Cassidy SB, Driscoll DJ. Prader-Willi syndrome. *Eur J Hum Genet* 2009;17:3-13.
- Irizary KA, Miller M, Freemark M, Haqq AM. Prader-Willi syndrome: Genetics, metabolomics, hormonal function, and new approaches to therapy. *Adv Pediatr* 2016;63:47-77.
- Veltman MW, Craig EE, Bolton PF. Autism spectrum disorders in Prader-Willi and Angelman syndromes: A systematic review. *Psychiatr Genet* 2005;15:243-54.
- Schwartz L, Holland A, Dykens E, Strong T, Roof E, Bohonowych J. Prader-Willi syndrome mental health research strategy workshop proceedings: The state of the science and future directions. *Orphanet J Rare Dis* 2016;11:131.
- Jauregi J, Laurier V, Copet P, Tauber M, Thuilleaux D. Behavioral profile of adults with Prader-Willi syndrome: Correlations with individual and environmental variables. *J Neurodev Disord* 2013;5:18.
- Sinnema M, Einfeld SL, Schrandt-Stumpel CT, Maaskant MA, Boer H, Curfs LM. Behavioral phenotype in adults with Prader-Willi syndrome. *Res Dev Disabil* 2011;32:604-12.
- Hiraiwa R, Maegaki Y, Oka A, Ohno K. Behavioral and psychiatric disorders in Prader-Willi syndrome: A population study in Japan. *Brain Dev* 2007;29:535-42.
- Butler JV, Whittington JE, Holland AJ, Boer H, Clarke D, Webb T. Prevalence of, and risk factors for, physical ill-health in people with Prader-Willi syndrome: A population-based study. *Dev Med Child Neurol* 2002;44:248-55.
- Monk D, Mackay DJ, Eggermann T, Maher ER, Riccio A. Genomic imprinting disorders: Lessons on how genome, epigenome and environment interact. *Nat Rev Genet* 2019;20:235-48.
- Peters J. The role of genomic imprinting in biology and disease: An expanding view. *Nat Rev Genet* 2014;15:517-30.
- Horsthemke B. In brief: Genomic imprinting and imprinting diseases. *J Pathol* 2014;232:485-7.
- Nicholls RD, Knoll JH, Butler MG, Karam S, Lalonde M. Genetic imprinting suggested by maternal heterodisomy in nondeletion Prader-Willi syndrome. *Nature* 1989;342:281-5.
- Meng L, Person RE, Beaudet AL. Ube3a-ATS is an atypical RNA polymerase II transcript that represses the paternal expression of Ube3a. *Hum Mol Genet* 2012;21:3001-12.
- Runte M, Kroisel PM, Gillissen-Kaesbach G, Varon R, Horn D, Cohen MY, et al. SNURF-SNRPN and UBE3A transcript levels in patients with Angelman syndrome. *Hum Genet* 2004;114:553-61.
- Ehrhart F, Janssen KJ, Coort SL, Evelo CT, Curfs LM. Prader-Willi syndrome and Angelman syndrome: Visualisation of the molecular pathways for two chromosomal disorders. *World J Biol Psychiatry* 2018;1-13.
- Zanella S, Watrin F, Mebarek S, Marly F, Roussel M, Gire C, et al. Necdin plays a role in the serotonergic modulation of the mouse respiratory network: Implication for Prader-Willi syndrome. *J Neurosci*

- 2008;28:1745-55.
33. Kuwajima T, Nishimura I, Yoshikawa K. Necdin promotes GABAergic neuron differentiation in cooperation with dlx homeodomain proteins. *J Neurosci* 2006;26:5383-92.
  34. Bervini S, Herzog H. Mouse models of Prader-Willi syndrome: A systematic review. *Front Neuroendocrinol* 2013;34:107-19.
  35. Lin HY, Lin SP, Yen JL, Lee YJ, Huang CY, Hung HY, et al. Prader-Willi syndrome in Taiwan. *Pediatr Int* 2007;49:375-9.
  36. Gillissen-Kaesbach G, Robinson W, Lohmann D, Kaya-Westerloh S, Passarge E, Horsthemke B. Genotype-phenotype correlation in a series of 167 deletion and non-deletion patients with Prader-Willi syndrome. *Hum Genet* 1995;96:638-43.
  37. Yang L, Zhan GD, Ding JJ, Wang HJ, Ma D, Huang GY, et al. Psychiatric illness and intellectual disability in the Prader-Willi syndrome with different molecular defects – A meta analysis. *PLoS One* 2013;8:e72640.
  38. Buiting K, Clayton-Smith J, Driscoll DJ, Gillissen-Kaesbach G, Kanber D, Schwinger E, et al. Clinical utility gene card for: Angelman Syndrome. *Eur J Hum Genet* 2015;23.
  39. Shaaya EA, Grocott OR, Laing O, Thibert RL. Seizure treatment in Angelman syndrome: A case series from the Angelman syndrome clinic at Massachusetts general hospital. *Epilepsy Behav* 2016;60:138-41.
  40. Thibert RL, Conant KD, Braun EK, Bruno P, Said RR, Nespeca MP, et al. Epilepsy in Angelman syndrome: A questionnaire-based assessment of the natural history and current treatment options. *Epilepsia* 2009;50:2369-76.
  41. Valente KD, Koiffmann CP, Fridman C, Varella M, Kok F, Andrade JQ, et al. Epilepsy in patients with Angelman syndrome caused by deletion of the chromosome 15q11-13. *Arch Neurol* 2006;63:122-8.
  42. Uemura N, Matsumoto A, Nakamura M, Watanabe K, Negoro T, Kumagai T, et al. Evolution of seizures and electroencephalographical findings in 23 cases of deletion type Angelman syndrome. *Brain Dev* 2005;27:383-8.
  43. Sueri C, Ferlazzo E, Elia M, Bonanni P, Randazzo G, Gasparini S, et al. Epilepsy and sleep disorders improve in adolescents and adults with Angelman syndrome: A multicenter study on 46 patients. *Epilepsy Behav* 2017;75:225-9.
  44. Wang PJ, Hou JW, Sue WC, Lee WT. Electroclinical characteristics of seizures-comparing Prader-willli syndrome with Angelman syndrome. *Brain Dev* 2005;27:101-7.
  45. Ruggieri M, McShane MA. Parental view of epilepsy in Angelman syndrome: A questionnaire study. *Arch Dis Child* 1998;79:423-6.
  46. Minassian BA, DeLorey TM, Olsen RW, Philippart M, Bronstein Y, Zhang Q, et al. Angelman syndrome: Correlations between epilepsy phenotypes and genotypes. *Ann Neurol* 1998;43:485-93.
  47. Takeshita E, Murakami N, Sakuta R, Nagai T. Evaluating the frequency and characteristics of seizures in 142 Japanese patients with Prader-Willi syndrome. *Am J Med Genet A* 2013;161A:2052-5.
  48. Vendrame M, Maski KP, Chatterjee M, Heshmati A, Krishnamoorthy K, Tan WH, et al. Epilepsy in Prader-Willi syndrome: Clinical characteristics and correlation to genotype. *Epilepsy Behav* 2010;19:306-10.
  49. Fan Z, Greenwood R, Fisher A, Pendyal S, Powell CM. Characteristics and frequency of seizure disorder in 56 patients with Prader-Willi syndrome. *Am J Med Genet A* 2009;149A:1581-4.
  50. Judson MC, Wallace ML, Sidorov MS, Burette AC, Gu B, van Woerden GM, et al. GABAergic neuron-specific loss of ube3a causes Angelman syndrome-like EEG abnormalities and enhances seizure susceptibility. *Neuron* 2016;90:56-69.
  51. Boyd SG, Harden A, Patton MA. The EEG in early diagnosis of the Angelman (happy puppet) syndrome. *Eur J Pediatr* 1988;147:508-13.
  52. Leyser M, Penna PS, de Almeida AC, Vasconcelos MM, Nascimento OJ. Revisiting epilepsy and the electroencephalogram patterns in Angelman syndrome. *Neurol Sci* 2014;35:701-5.
  53. Laan LA, Renier WO, Arts WF, Buntinx IM, vd Burgt IJ, Stroink H, et al. Evolution of epilepsy and EEG findings in Angelman syndrome. *Epilepsia* 1997;38:195-9.
  54. Yum MS, Lee EH, Kim JH, Ko TS, Yoo HW. Implications of slow waves and shifting epileptiform discharges in Angelman syndrome. *Brain Dev* 2013;35:245-51.
  55. Pelc K, Boyd SG, Cheron G, Dan B. Epilepsy in Angelman syndrome. *Seizure* 2008;17:211-7.
  56. Valente KD, Andrade JQ, Grossmann RM, Kok F, Fridman C, Koiffmann CP, et al. Angelman syndrome: Difficulties in EEG pattern recognition and possible misinterpretations. *Epilepsia* 2003;44:1051-63.
  57. Franz DN, Glauser TA, Tudor C, Williams S. Topiramate therapy of epilepsy associated with Angelman's syndrome. *Neurology* 2000;54:1185-8.
  58. Tan WH, Bird LM, Sadhwani A, Barbieri-Welge RL, Skinner SA, Horowitz LT, et al. A randomized controlled trial of levodopa in patients with Angelman syndrome. *Am J Med Genet A* 2018;176:1099-107.
  59. Ruiz-Antoran B, Sancho-López A, Cazorla-Calleja R, López-Pájaro LF, Leiva Á, Iglesias-Escalera G, et al. A randomized placebo controlled clinical trial to evaluate the efficacy and safety of minocycline in patients with Angelman syndrome (A-MANECE study). *Orphanet J Rare Dis* 2018;13:144.
  60. Meng L, Ward AJ, Chun S, Bennett CF, Beaudet AL, Rigo F. Towards a therapy for Angelman syndrome by targeting a long non-coding RNA. *Nature* 2015;518:409-12.
  61. Huang HS, Allen JA, Mabb AM, King IF, Miriyala J, Taylor-Blake B, et al. Topoisomerase inhibitors unsilence the dormant allele of Ube3a in neurons. *Nature* 2011;481:185-9.
  62. Salehi P, Hsu I, Azen CG, Mittelman SD, Geffner ME, Jeandron D. Effects of exenatide on weight and appetite in overweight adolescents and young adults with Prader-Willi syndrome. *Pediatr Obes* 2017;12:221-8.
  63. McCandless SE, Yanovski JA, Miller J, Fu C, Bird LM, Salehi P, et al. Effects of MetAP2 inhibition on hyperphagia and body weight in Prader-Willi syndrome: A randomized, double-blind, placebo-controlled trial. *Diabetes Obes Metab* 2017;19:1751-61.
  64. Schaller F, Watrin F, Sturny R, Massacrier A, Szepietowski P, Muscatelli F. A single postnatal injection of oxytocin rescues the lethal feeding behaviour in mouse newborns deficient for the imprinted Magel2 gene. *Hum Mol Genet* 2010;19:4895-905.
  65. Swaab DF, Purba JS, Hofman MA. Alterations in the hypothalamic paraventricular nucleus and its oxytocin neurons (putative satiety cells) in Prader-Willi syndrome: A study of five cases. *J Clin Endocrinol Metab* 1995;80:573-9.
  66. Miller JL, Tamura R, Butler MG, Kimonis V, Sulsona C, Gold JA, et al. Oxytocin treatment in children with Prader-Willi syndrome: A double-blind, placebo-controlled, crossover study. *Am J Med Genet A* 2017;173:1243-50.